

▶ DET 1: Pipe connections

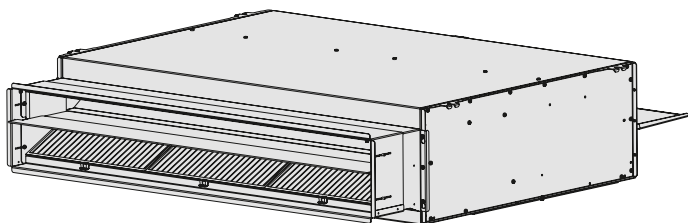

▶ Conceptual drawings

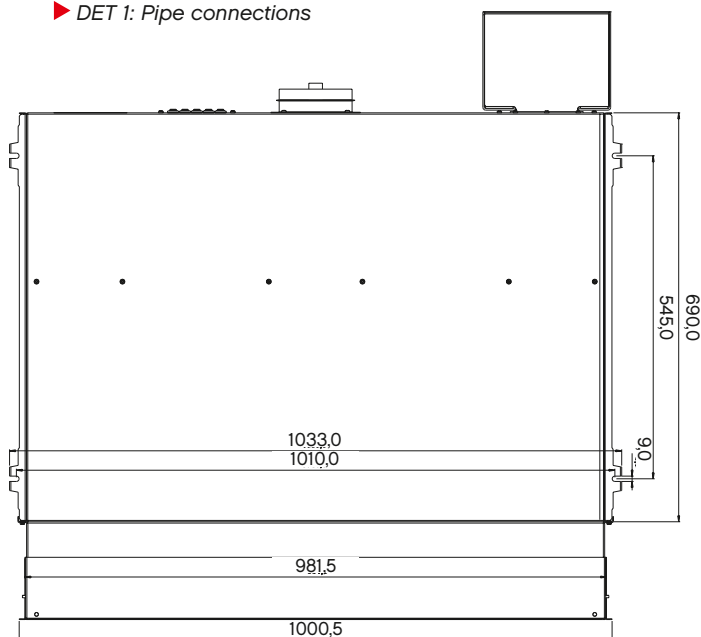

▶ Top view

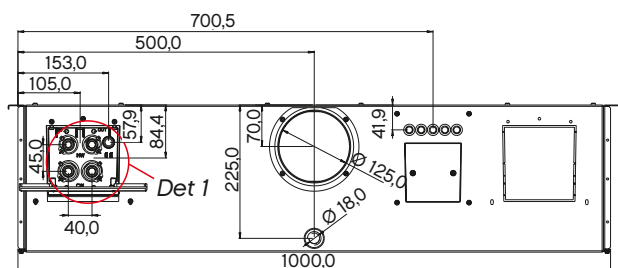

▶ Rear view, connections

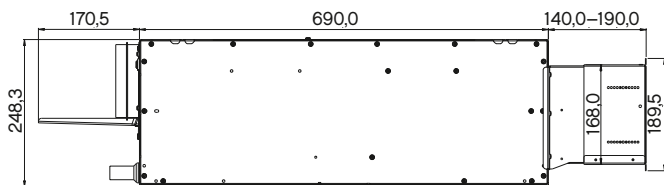

▶ Side view

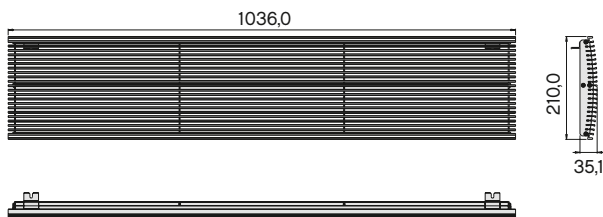

▶ Grille

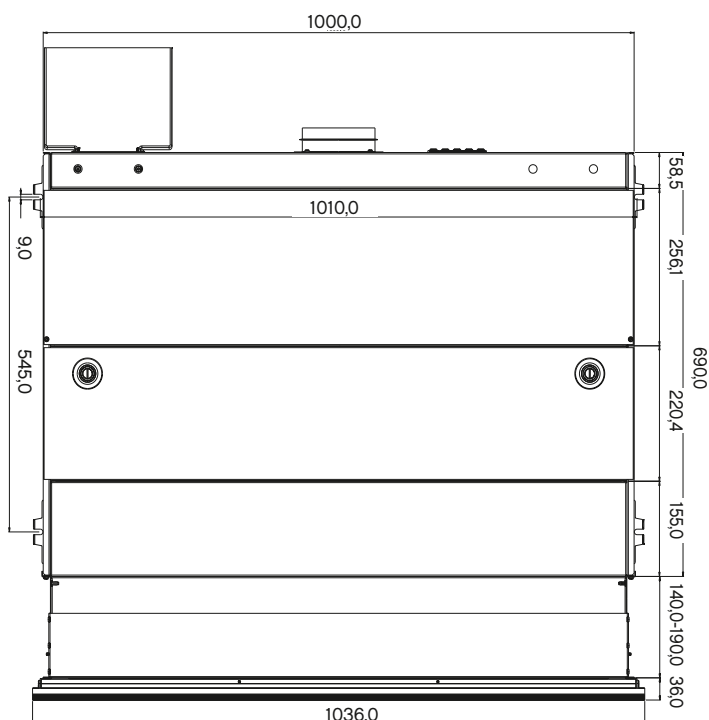

▶ Bottom view

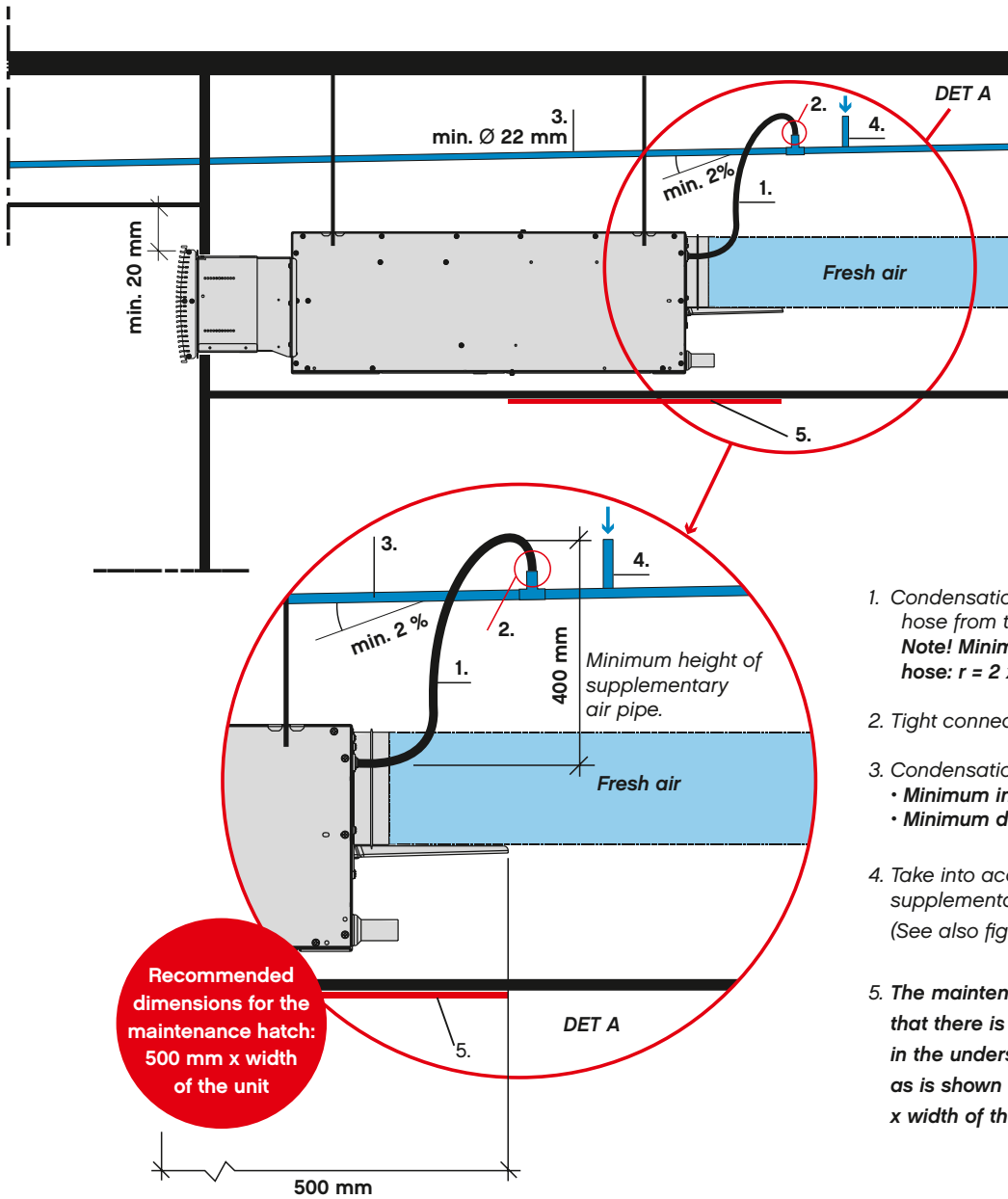

1. Condensation water hose from the unit.
Note! Minimum radius of the hose: $r = 2 \times \text{pipe diam}$
2. Tight connection.
3. Condensation sewerage **Note!**
 - Minimum inclination 2 %.
 - Minimum diameter 22 mm.
4. Take into account the availability of supplementary air, shown by arrow. (See also figure 9)
5. The maintenance hatch: Make sure that there is a maintenance hatch in the underside of the false ceiling as is shown in the picture (500 mm x width of the unit).

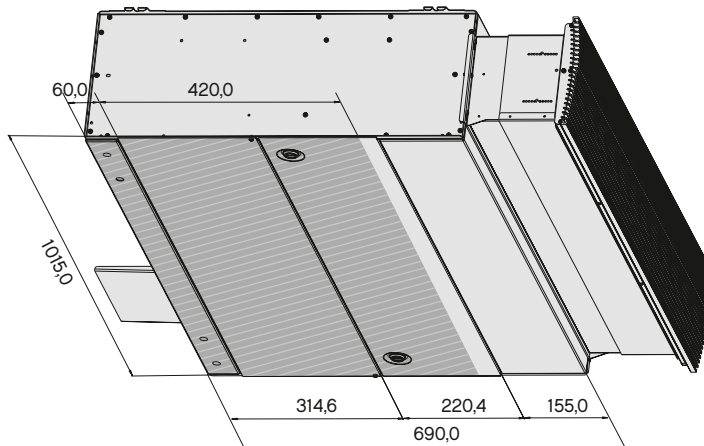

▶ Access handles under the unit