



Precision air conditioning units

Chiller precision air conditioning units



Chiller units are manufactured for performance and reliability using a combination of high tech design, manufacturing and testing skills coupled with genuine attention to detail and craftsmanship.

The precision air conditioners are designed for optimum performance in high sensible heat environments such as telecommunications and computer rooms.

They offer a wide variety of capacities, configurations and air patterns within an extremely compact cabinet size. Minimal floor space required and dramatically reduced service clearance due to front access for all routinely serviced components. It also enables installation in a corner, closet or next to another unit.

Excellent sound performance due to good acoustic insulation (up to 100 mm).

Microprocessor controller provides continuous control of cooling, heating, humidification and dehumidification to meet the required room environment conditions.

Models:

AUC/ADC:	DX system and air cooled condenser. Upflow and downflow.
WUC/WDC:	DX system and water cooled condenser. Upflow and downflow.
CWUC/CWDC:	Chilled water system. Upflow and downflow.

Specified DX models can be delivered with rear air intake.

Condensers (CCS) and dry coolers (CCSG) are available for different sound levels and ambient temperatures.

Other features and options

Discharge plenum for upflow units.

Choice of filter by filtration class.

Height adjustable base frame for raised floor installations.

Stainless steel condensate tray.

Under floor mounted stainless steel tray.

Water leak detector.

Sensors for fire and smoke detection.

Rear air intake frame (CWUC and CWDC units).

Connections for status and alarm transfer.

Acoustic insulated front access panel.

Connections to Building Management System.



Upflow units
without discharge plenum.



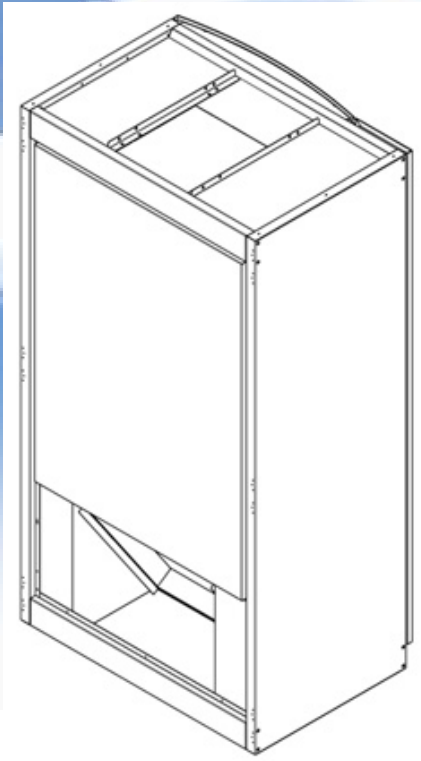

Unit with rear air intake.

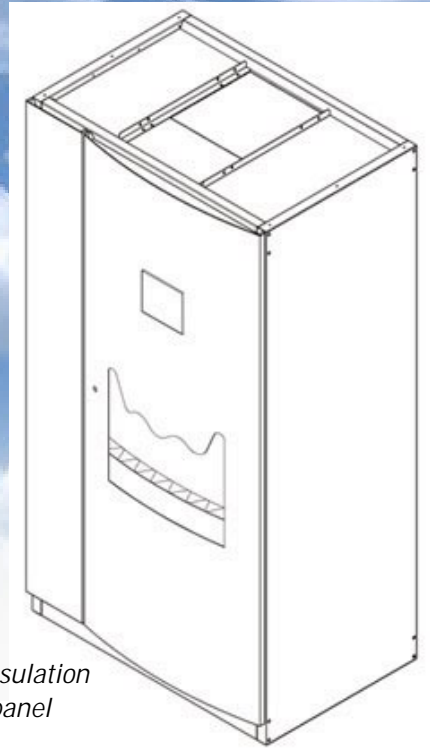

Acoustic insulation of access panel



Technical data - Refrigerant R407C (DX-coil)

AUC = Air cooled, upflow ADC = Air cooled, downflow
 WUC = Water cooled, upflow WDC = Water cooled, downflow

Indoor temperature 24°C, 50 %, condensing temperature 45°C

Model	020-1	030-1	035-1	040-1	050-1	050-2	060-1	060-2
Cooling capacity kW	8	11	15	18	22	22	24	24
Sensible capacity kW	6	9	12	16	18	18	20	20
Condensing capacity kW	11	14	20	23	29	29	31	31
Compressor (hermetic) 400V-3ph-50Hz								
No	1	1	1	1	1	2	1	2
Power input kW	2,4	3,3	4,5	5,5	6,6	6,6	8,5	8,5
Centrifugal fans 230V-1Ph-50Hz (direct drive motor)								
No	1	1	1	1	1	1	1	1
Airflow m³/s	0,33	0,53	0,75	1,06	1,06	1,06	1,25	1,25
External static pressure Pa	30	30	30	30	30	30	30	30
Power input/motor kW	0,35	0,35	0,35	0,75	0,75	0,75	0,75	0,75
Filter EU 5								
No	1	1	1	1	1	1	1	1
Dimensions: upflow	600*400	600*400	600*400	560*600	560*600	560*600	560*600	560*600
Dimensions: downflow	600*400	600*400	600*400	560*650	560*650	560*650	560*650	560*650
Electric heater 400V-3Ph-50Hz								
Heating capacity kW	3	3	3	5	5	5	5	5
No of heater element	1	1	1	2	2	2	2	2
Capacity steps	1	1	1	2	2	2	2	2
Humidifier 400V-3Ph-50Hz								
Steam capacity kg/h	3,0	3,0	4,7	4,7	4,7	4,7	4,7	4,7
Power input kW	2,2	2,2	3,4	3,4	3,4	3,4	3,4	3,4
Dimensions and weight								
Length mm	760	760	760	1010	1010	1010	1010	1010
Depth mm	720	720	720	720	720	720	720	720
Height mm	1920	1920	1920	1920	1920	1920	1920	1920
Weight kg	160	160	170	220	260	260	270	270
Discharge plenum height 500 mm (add to height, for AUC and WUC units)								
Pipe connections								
Humidifier mm	6	6	6	6	6	6	6	6
Drain mm	32	32	32	32	32	32	32	32
Total power input 400V-3ph-50Hz								
Model A and E kW	2,8	3,7	5,0	6,3	7,4	7,4	9,3	9,3
Model B kW	5,8	6,7	8,0	10,3	12,4	12,4	14,3	14,3
Model C kW	5,0	5,9	8,4	9,7	10,8	10,8	12,7	12,7
Model D kW	8,0	8,9	11,4	14,7	15,8	15,8	17,7	17,7

A = Cooling only
 B = Cooling + electrical heating
 C = Cooling + humidification

D = Cooling + electrical heating + humidification + dehumidification
 E = Heating only (water coil)

Technical data - Refrigerant R407C (DX-coil)

AUC = Air cooled, upflow ADC = Air cooled, downflow
WUC = Water cooled, upflow WDC = Water cooled, downflow

Indoor temperature 24°C, 50 %, condensing temperature 45°C

Model	075-2	090-2	110-2	130-2	140-2
Cooling capacity kW	30	37	45	50	58
Sensible capacity kW	29	33	37	46	49
Condensing capacity kW	39	48	59	65	75
Compressor (hermetic) 400V-3ph-50Hz					
No.	2	2	2	2	2
Power input kW	9	11,1	13,5	15	18
Centrifugal fans 230V-1Ph-50Hz (direct drive motor)					
No.	1	2	2	3	3
Airflow m³/s	2,3	2,3	2,3	3,18	3,18
External static pressure Pa	30	30	30	30	30
Power input/motor kW	0,75	1,5	1,5	2,25	2,25
Filter EU 5					
No.	2	2	2	3	3
Dimensions: upflow	600*600	600*600	600*600	600*600	600*600
Dimensions: downflow	560*650	560*650	560*650	560*650	560*650
Electric heater 400V-3Ph-50Hz					
Heating capacity kW	5	6,6	12	12	12
No. of heater element	2	2	4	4	4
Capacity steps	2	2	3	3	3
Humidifier 400V-3Ph-50Hz					
Steam capacity kg/h	4,7	4,7	9,4	9,4	9,4
Power input kW	3,4	3,4	6,9	6,9	6,9
Dimensions and weight					
Length mm	1775	1775	1775	2300	2300
Depth mm	720	720	720	720	720
Height mm	1920	1920	1920	1920	1920
Weight kg	280	465	475	490	490
Discharge plenum height 500 mm (add to height, for AUC and WUC units)					
Pipe connections					
Humidifier mm	6	6	6	6	6
Drain mm	32	32	32	32	32
Total power input 400V-3ph-50Hz					
Model A and E kW	11,3	12,6	15,0	17,5	21,0
Model B kW	16,3	19,2	27,0	29,3	33,0
Model C kW	14,7	17,3	21,9	24,2	27,9
Model D kW	19,7	23,9	33,9	36,2	39,9

A = Cooling only
B = Cooling + electrical heating
C = Cooling + humidification

D = Cooling+ electrical heating + humidification + dehumidification
E = Heating only (water coil)

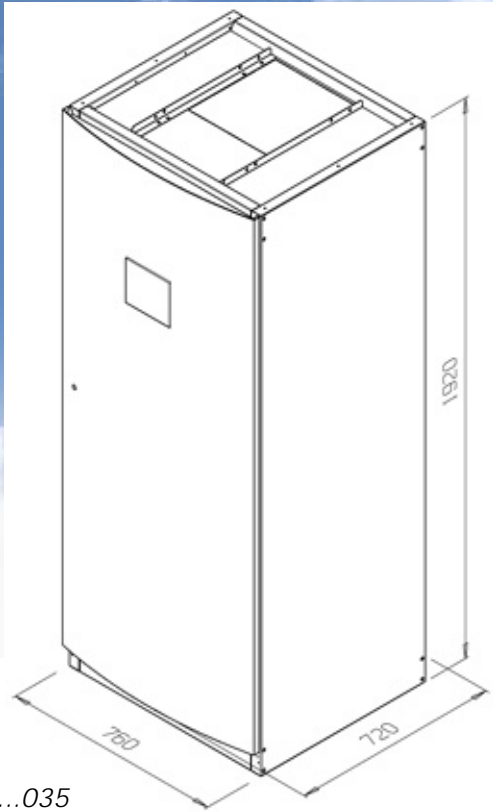

Model 020...035

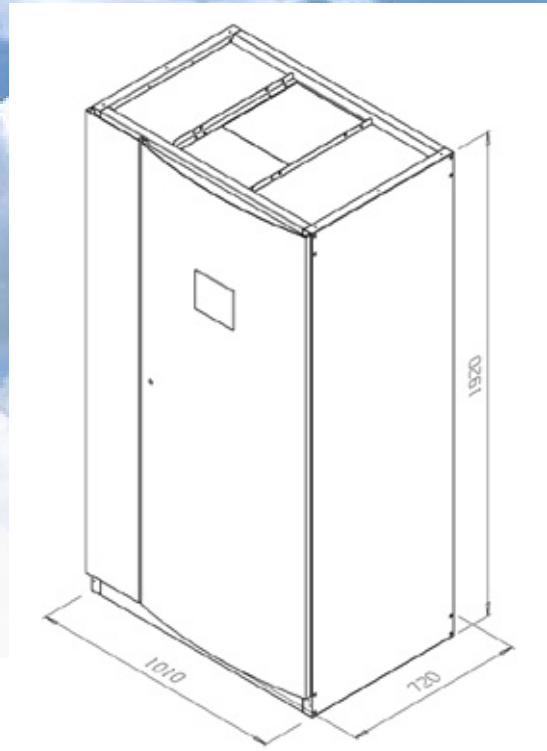

Model 040...070

Depth of unit includes acoustic insulated access panel. The panel is removable.

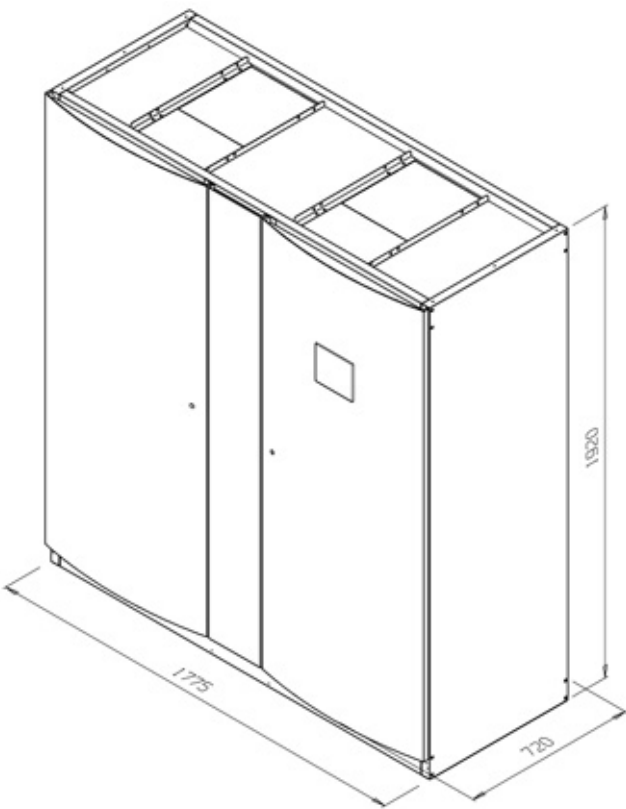

Model 075...110

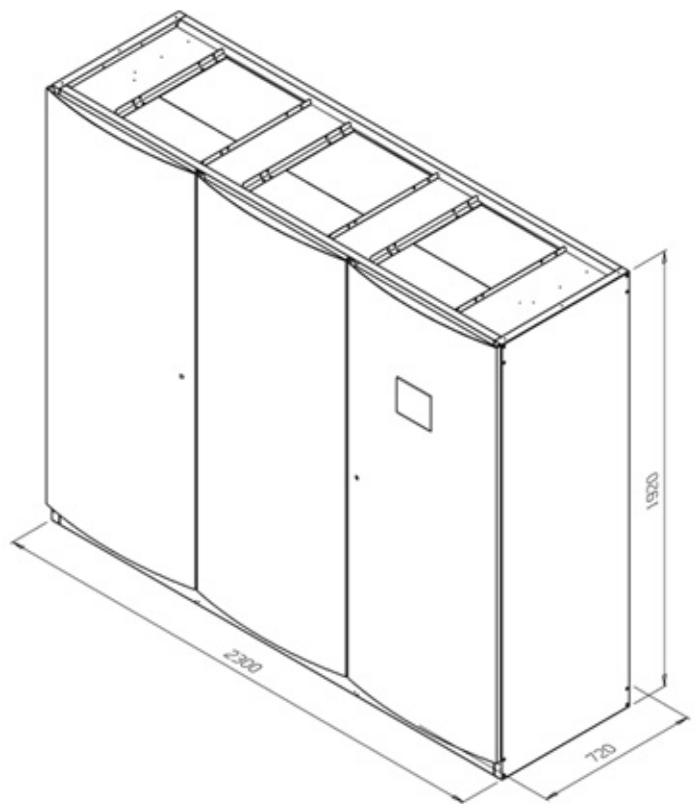

Model 130...190

Condenser and dry-cooler selection AUC, ADC ja WUC, WDC -units

Unit model	020-1	030-1	035-1	040-1	050-1	050-2	060-1	060-2
Condensing duty kW	11	14	20	23	29	29	31	31
Condensers (ambient air temperature 30°C, condensing temperature 45°C)								
Option 1	<u>CCS 3-9</u>	<u>CCS 5-9</u>	<u>CCS 7-9</u>	<u>CCS 7-9</u>	<u>CCS 8-9</u>	<u>CCS 8-9</u>	<u>CCS 8-11</u>	<u>CCS 8-11</u>
Sound power level dB(A), 10 m	41	42	44	44	45	45	48	48
Option 2	<u>CCS 3-11</u>	<u>CCS 3-14</u>	<u>CCS 5-14</u>	<u>CCS 6-14</u>	<u>CCS 6-14</u>	<u>CCS 6-14</u>	<u>CCS 7-14</u>	<u>CCS 7-14</u>
Sound power level dB(A), 10 m	45	51	52	55	55	55	54	54

Unit model	020-1	030-1	035-1	040-1	050-1	050-2	060-1	060-2
Condensing duty kW	11	14	20	23	29	29	31	31
Dry-coolers (ambient air temperature 30°C, working fluid 37/42°C, 35 % propylene glycol)								
Option 1	<u>CCSG3-11-25-5</u>	<u>CCSG5-11-32-6</u>	<u>CCSG8-9-40-9</u>	<u>CCSG8-9-40-9</u>	<u>CCSG9-9-40-11</u>	<u>CCSG9-9-40-11</u>	<u>CCSG9-9-40-11</u>	<u>CCSG9-9-40-11</u>
Sound power level dB(A), 10 m	45	45	45	45	45	45	45	45
Flow rate l/s	0,6	0,9	1,2	1,2	1,6	1,6	1,6	1,6
Pressure drop kPa	22,9	36,1	33,6	33,6	37,3	37,3	37,3	37,3
Option 2	<u>CCSG3-14-25-5</u>	<u>CCSG5-14-25-5</u>	<u>CCSG6-14-40-11</u>	<u>CCSG6-14-40-11</u>	<u>CCSG8-14-32-9</u>	<u>CCSG8-14-32-9</u>	<u>CCSG8-14-32-9</u>	<u>CCSG8-14-32-9</u>
Sound power level dB(A), 10 m	51	52	55	55	55	55	55	55
Flow rate l/s	0,7	0,7	1,5	1,5	1,2	1,2	1,2	1,2
Pressure drop kPa	27,7	28,0	30,0	30,0	30,7	30,7	30,7	30,7

Unit model	075-2	090-2	110-2	130-2	140-2
Condensing duty kW	39	48	59	65	75
Condensers (ambient air temperature 30°C, condensing temperature 45°C)					
Option 1	<u>CCS 9-9</u>	<u>CCS 10-11</u>	<u>CCS 12-9</u>	<u>CCS 13-9</u>	<u>CCS 14-9</u>
Sound power level dB(A), 10 m	45	49	48	48	49
Option 2	<u>CCS 8-14</u>	<u>CCS 9-14</u>	<u>CCS 10-14</u>	<u>CCS 11-14</u>	<u>CCS 12-14</u>
Sound power level dB(A), 10 m	55	58	56	60	58
Dry-coolers (ambient air temperature 30°C, working fluid 37/42°C, 35 % propylene glycol)					
Option 1	<u>CCSG10-11-50-18</u>	<u>CCSG15-7-50-16</u>	<u>CCSG14-9-50-21</u>	<u>CCSG15-9-50-22</u>	<u>CCSG16-11-65-25</u>
Sound power level dB(A), 10 m	41	41	49	49	51
Flow rate l/s	2,5	2,1	2,9	3	3,4
Pressure drop kPa	29	39,1	35,6	32,5	30,9
Option 2	<u>CCSG9-14-50-15</u>	<u>CCSG10-14-50-19</u>	<u>CCSG13-11-50-21</u>	<u>CCSG14-11-65-23</u>	<u>CCSG14-14-65-26</u>
Sound power level dB(A), 10 m	58	56	54	54	51
Flow rate l/s	2,1	2,6	2,9	3,1	3,5
Pressure drop kPa	30,3	29,2	34,5	34,1	27,6

Technical data

Air-Cooled Condensers

R 407C

Model		7			9			11			14		
CCS	Fans No.	Capacity kW	Airflow m ³ /s	S.L. dB(A)	Capacity kW	Airflow m ³ /s	S.L. dB(A)	Capacity kW	Airflow m ³ /s	S.L. dB(A)	Capacity kW	Airflow m ³ /s	S.L. dB(A)
1	1 X 350	-	-	-	-	-	-	5,3	0,45	36	6,5	0,60	42
2	1 x 350	-	-	-	-	-	-	7,3	0,60	36	8,3	0,70	42
3	1 x 450	7,5	0,60	33	9,5	0,82	41	11,3	1,05	45	12,9	1,30	51
4	1 x 450	8,9	0,70	33	11,0	0,92	41	12,9	1,16	45	15,3	1,50	51
5	1 x 500	10,1	0,79	33	13,2	1,12	42	14,6	1,30	45	18,8	1,90	52
6	1 x 560	15,1	1,19	34	20,3	1,74	42	23,4	2,12	48	26,4	2,56	55
7	2 x 450	18,7	1,47	36	22,0	1,81	44	26,3	2,30	48	31,9	3,00	54
8	2 x 500	20,4	1,58	36	26,9	2,25	45	30,1	2,63	48	39,7	3,97	55
9	2 x 560	27,3	2,15	37	35,3	3,00	45	39,4	3,50	51	46,4	4,50	58
10	3 x 500	30,7	2,40	38	39,9	3,36	46	44,6	3,90	49	57,0	5,70	56
11	3 x 560	38,7	3,10	39	51,1	4,50	46	56,8	5,30	52	65,4	6,60	60
12	4 x 500	39,0	3,10	40	52,5	4,58	48	58,0	5,30	50	70,6	7,20	58
13	4 x 560	49,5	4,00	40	63,6	5,60	48	71,6	6,60	54	84,2	8,50	61
14	4 x 560	54,5	4,40	41	71,0	6,20	49	79,1	7,30	54	93,1	9,40	61
15	2 x 3 x 500	58,6	4,65	41	78,9	6,90	49	86,2	7,80	51	104,1	10,50	60
16	2 x 3 x 500	63,0	5,00	41	84,8	7,40	49	92,8	8,40	51	112,0	11,30	60
17	2 x 3 x 500	70,3	5,50	41	92,5	7,80	49	103,1	9,00	51	121,1	11,50	60
18	2 x 3 x 560	79,9	6,40	42	99,4	8,60	49	112,7	10,30	56	133,1	13,30	63

Fan and motor specifications

Model		7			9			11			14		
Fan D mm	Power supply V	Airflow 1/min	PI. kW	Current A	Airflow 1/min	PI. kW	Current A	Airflow 1/min	PI. kW	Current A	Airflow 1/min	PI. kW	Current A
350	230	-	-	-	-	-	-	-	-	-	1380	0,145	0,64
450	230	-	-	-	-	-	-	-	-	-	1325	0,480	2,30
350	400	-	-	-	-	-	-	1080	0,12	0,20	1380	0,145	0,38
450	400	710	0,11	0,30	920	0,17	0,52	1040	0,34	0,60	1340	0,450	0,90
500	400	620	0,14	0,32	880	0,24	0,60	1035	0,46	0,80	1330	0,650	1,15
560	400	620	0,20	0,48	860	0,39	0,92	1030	0,61	1,05	1330	0,800	1,55

The duties in the tables are according to ENV 327: air on +25°C and condensing temperature +40°C. Power input at +40°C and max. current at -30°C.

We reserve the right to change the specification in this brochure without prior notice.

Sound power level dB(A) at 10 m distance according to ISO 3741.

CCS dimensions

Horizontal mounting - Vertical flow = H

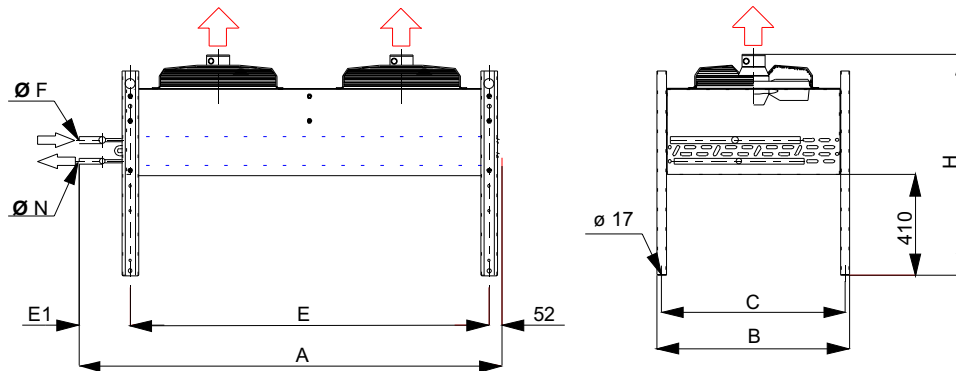

Vertical mounting - Horizontal flow = V

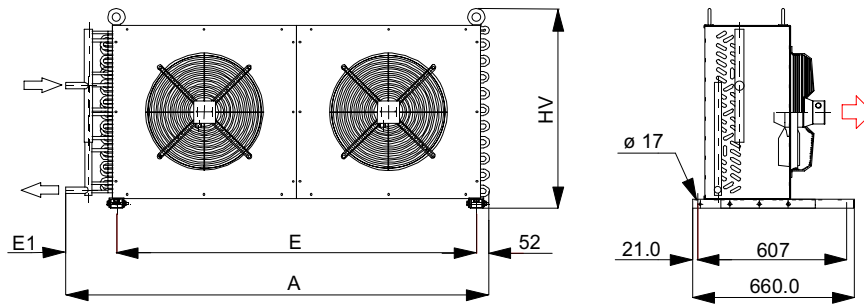

CCS	Dimensions Installation				Dimensions Outside			Connections		Sur-face m ²	Int. Volume l	Weight kg
	A	E	E1	C	B	H	HV	Ø F	Ø N			
1	590	417	120	555	591	833	620	"5/8"	"5/8"	20,8	3,5	40
2	920	667	200	555	591	833	620	"5/8"	"5/8"	32,4	5,0	49
3	770	517	200	750	786	900	820	"5/8"	"5/8"	35,6	6,0	60
4	920	667	200	750	786	900	820	22	"5/8"	45,3	7,3	63
5	920	667	200	850	886	900	920	22	"5/8"	51,8	8,5	70
6	1080	817	210	1050	1086	900	1120	28	"5/8"	78,6	13,0	91
7	1740	1467	216	750	786	900	820	28	22	97,1	14,8	113
8	1740	1467	216	850	886	900	920	35	28	110,9	17,0	127
9	1740	1467	216	1050	1086	900	1120	35	28	138,7	21,5	163
10	2444	2167	225	850	886	900	940	35	28	162,7	25,1	187
11	2444	2167	225	950	986	900	1040	42	35	183	28,7	208
12	2855	2567	235	850	886	900	940	42	35	192	29,5	233
13	3055	2767	235	950	986	900	1040	42	35	233	35,6	261
14	3055	2767	235	1050	1086	900	1140	42	35	259	40,3	286
15	2665	2367	245	1350	1386	900	1440	42	42	288	46,0	306
16	2665	2367	245	1450	1486	900	1540	54	42	310	52,0	322
17	2965	2667	245	1550	1586	900	1640	54	42	375	62,0	330
18	2965	2667	245	1550	1586	900	1640	54	42	375	62,0	380

Operation diagrams

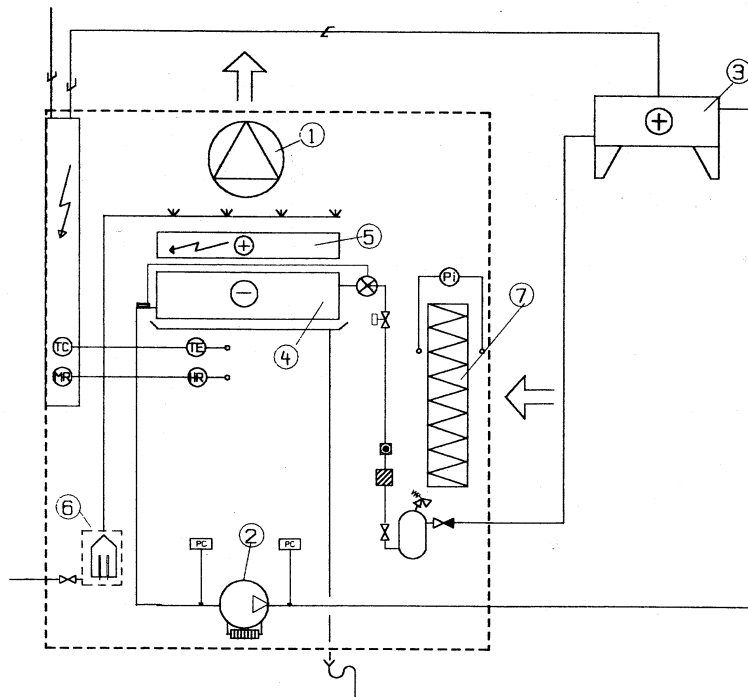

1 Upflow unit with air-cooled condenser

Figure 1 and 2:

- | | |
|--------------|-------------------|
| 1 Fan | 5 Electric heater |
| 2 Compressor | 6 Humidifier |
| 3 Condenser | 7 Filter |
| 4 Evaporator | |

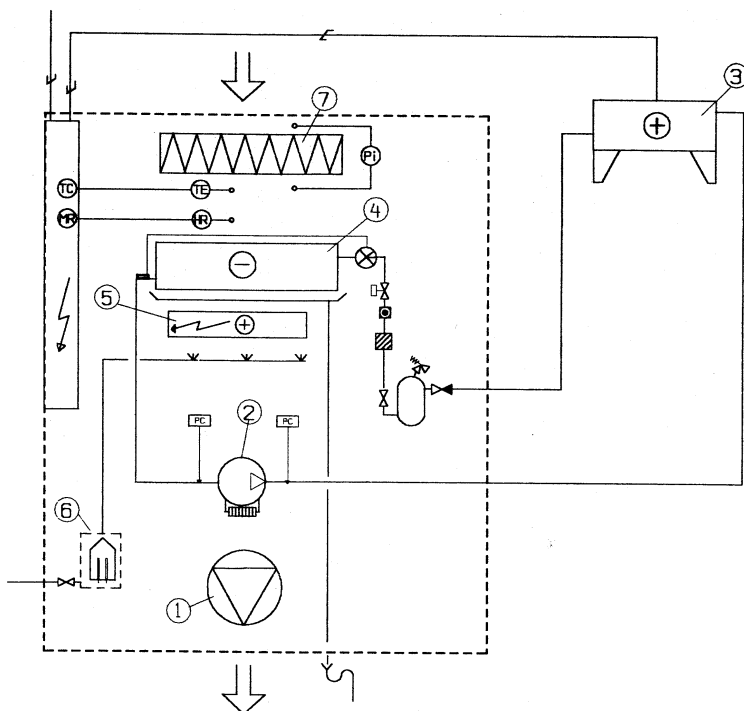

2 Downflow unit with air-cooled condenser

- Cooling
- Heating
- Dehumidification
- Humidification

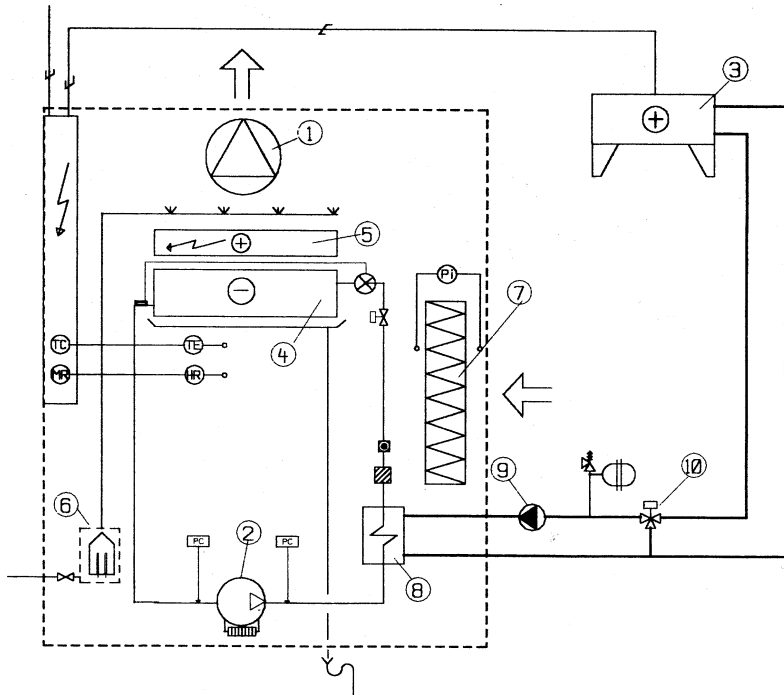

3 Upflow unit with water-cooled condenser

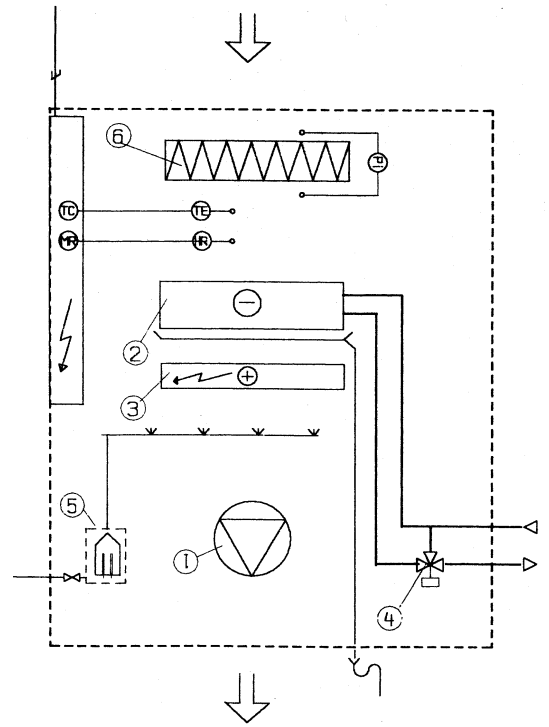

5 Downflow unit for chilled water

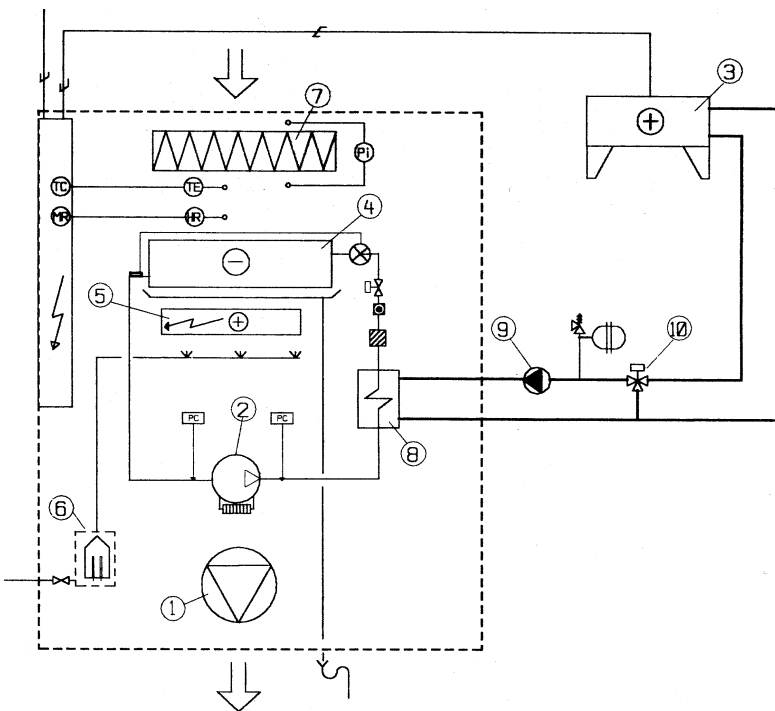

4 Downflow unit with water-cooled condenser

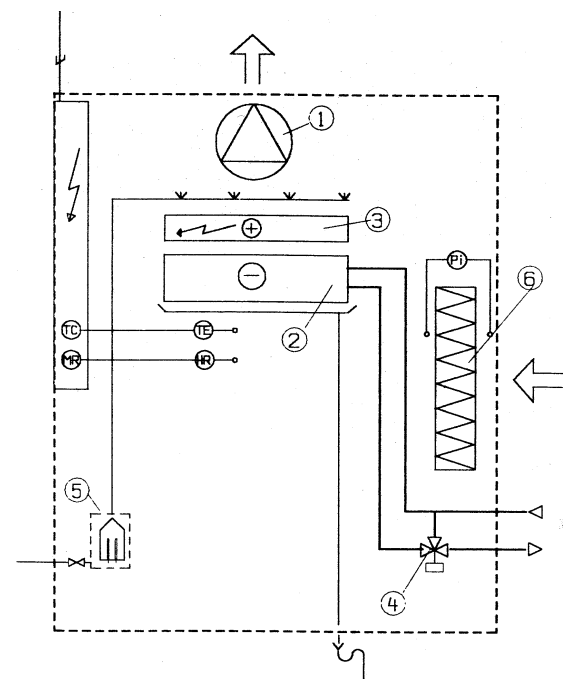

6 Upflow unit for chilled water

Figure 3 and 4:

- | | |
|-------------------|--------------------------|
| 1 Fan | 6 Humidifier |
| 2 Compressor | 7 Filter |
| 3 Dry cooler | 8 Water cooled condenser |
| 4 Evaporator | 9 Pump |
| 5 Electric heater | 10 3-way valve |

Figure 5 and 6:

- | |
|-------------------|
| 1 Fan |
| 2 Cooling coil |
| 3 Electric heater |
| 4 3-way valve |
| 5 Humidifier |
| 6 Filter |

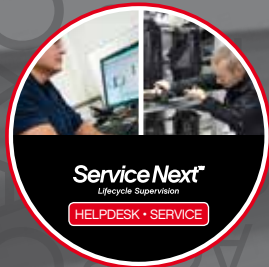

OUR SALES AND MAINTENANCE NETWORK AT YOUR SERVICE

Chiller Oy is one of Europe's leading manufacturers of energy-efficient and optimized air-conditioning solutions. Design and service are always based on the customers' specific requirements. For more information, please contact our head office or foreign business partners.

► *Read more: www.chiller.fi*

Head office

Chiller Oy
Louhostie 2
FI-04300 Tuusula
FINLAND

Tel. + 358 9 2747 670
info@chiller.fi
www.chiller.fi

Sweden

Chiller Sverige AB
Stockholm
Tel. +46 8 54 50 2080
info@chillersverige.se
www.chillersverige.se

Forsberg & Tibell Kyl AB
Jönköping
Tel. +46 36 132 650
info@kyla.nu
www.kyla.nu

Norway

Chiller Norge AS
Oslo
Tel. +47 95 86 89 18
rune.nordgard@chillernorge.no
www.chillernorge.no

Estonia

Climaref OÜ
Tartu
kaarel@climaref.ee
www.climaref.ee

Lithuania

UAB Leslat
Kaunas
leslat@takas.lt
www.leslat.lt

Poland

StepSystems Sp. z o.o.
Radom
biuro@stepsystems.pl
www.stepsystems.pl



ServiceNext™
Overall Concept